



# 0.8MM THICK INDUSTRIAL STEEL ROLLER SHUTTERS

SERIES 75 & SERIES 100 ROLLFORMED SLATS



Solid 75mm slats



Solid 100mm slats

Mirage steel roller shutters are available with 75mm or 100mm wide slats, cater for the largest of openings and provide enhanced security. Additional strength is obtained by using windlock clips and guides.

## APPLICATIONS

Mirage steel roller shutters are widely used in loading docks, car park entries and storage areas in warehouses, factories, mining, schools, tertiary institutions, correctional centres, defence force facilities, police stations and courthouses.

The Mirage steel roller shutters can be modified to meet with cyclonic or high windload specifications, fulfill high security requirements and also be used for high cycle usage.

Call 1800 465 599 or visit [www.miragedoors.com.au](http://www.miragedoors.com.au)

A MEMBER OF THE



## RECOMMENDED SPECIFICATIONS

S75 and S100 Steel Roller Shutters as manufactured by Mirage Doors.

### CURTAIN

The standard slat supply is solid. If ventilation or viewing is a requirement, the following options are available:

#### Available with S100 Slats only

Slotted Slats - Any number of the slats can be punched with a 138mm wide x 40mm high hole at standard pitch. This gives effective 20% ventilation per slat.

#### Available with S75 and S100 Slats

Multi-hole Slats - The slats can also be continuously perforated with 2.41mm diameter holes @ 3.66mm staggered centres. This gives effective 33% ventilation per slat (100mm) and 27% ventilation per slat (75mm). The inclusion of powdercoat will reduce this air flow slightly.

### SERIES 75 & SERIES 100 BOTTOM RAIL

- Extruded aluminium T – section (Standard);
- An optional 80mm x 40mm steel galvanised box section is available;
- Weatherseals are an optional extra on all bottom rail types.

### SIZE

Maximum shutter sizes:

- S75 - 6000mm wide x 6000mm high;
- S100 - 10000mm wide x 8000mm high.

### OPERATION

- Manual by hand (up to 6m<sup>2</sup>);
- Chain operation (up to 25.0m<sup>2</sup>);
- Electric operation is by a 1 H.P. / 1.5 H.P. / 2.0 H.P. single / 3 phase motor / gearbox, reversing contactor and an up, down, stop standard controller. This includes emergency chain operation in the event of power failure. All wiring, setting of the limit switches and commissioning of the Mirage electrical components, and provision of a suitable power supply is by others (wiring can be organized on request).
- Alternately, electric operation by a direct drive motorisation incorporating a springless drum and brake motor. Includes a standard up, down & stop controller and an emergency chain operation in the event of power failure. This is strongly recommended for high cycle shutters exceeding 40 operations per day.

### LOCKING

- Sliding padbolts (inside OR outside) - padlocks by others. (Note that manual locks are not recommended for motorised shutters unless a safety switch is fitted).
- NOTE: For motorised shutters, the motor provides locking security.

### DRUM

The drum shall be manufactured from a seamless steel tube and attached to end caps. Helical coil oil tempered springs will be fitted to an axle inside the drum tube. The drum shall revolve on steel bearings.

### SLATS

Slats are 75mm or 100mm high and are available in two material gauges – 0.8mm or 1.0mm.

### GUIDES

- Standard 60mm x 37mm channel;
- Optional 100mm x 38mm channel;
- Windlock guides 103mm x 47mm.

### COMPLIANCE TO WINDLOAD SPECIFICATIONS

The S75 and S100 roller shutters are available with the option of windlock clips every 4th slat or every 2nd slat.

### BRACKET

The brackets are fabricated from mild steel and supplied in a prime paint finish.

### FINISH

- Galvabond steel (standard)
- Polyester powdercoat colours (selected from manufacturers powdercoat colour charts). Please note that Metallic or Pearl powdercoat finishes are not recommended for roller shutter products.

### OPTIONAL CONTROLS FOR MOTORISED DOORS

Steel roller shutters may be upgraded to include logic control boxes, photo - electric beam protection and / or hand transmitters. This is appropriate for car park entry or high security applications.

### INSTALLATION AND CLEARANCE DETAILS

Refer to Technical Data Sheets 8A, 8B, 9A, 9B, 9C, 9D & 9E.

### TIPS FOR ARCHITECTS, SHOPFITTERS & BUILDERS

- Preparation of openings to suit the Series 75 & Series 100 roller shutter is by others. The shutter must not be installed to hollow stud walls. Refer to the Technical Data sheets to ensure adequate opening preparation;
- If required, provision of jambs, cladding of columns, bulkheads and ceiling slot adjustments are by others;
- The architect must always specify the intended usage of shutters. This will enable appropriate drum and motor selections to be made;
- The multi - hole perforation process removes much of the Galvabond protection off the slat. As a result, premature surface corrosion may occur. This is not covered by warranty.

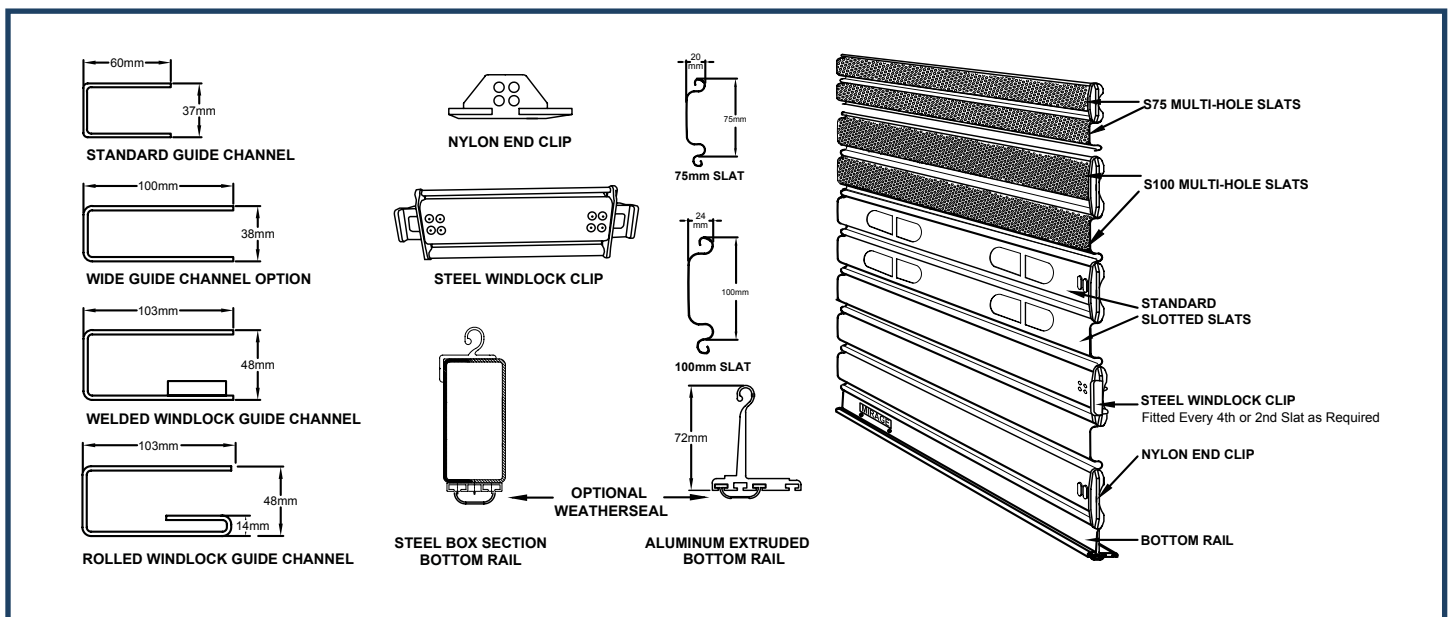

Mirage Doors has a continuous program of product development and reserves the right to change specifications at any time without notice.